



## VYHLÁSENIE O PARAMETROCH

### DoP 0233

pre fischer chemický kotviaci systém FIS V Plus (Malta pre dodatočne nainštalované armovacie spoje)

SK

- |   |  |  |
|---|--|--|
| 1. <u>Jedinečný identifikačný kód typu výrobku:</u>   | <b>DoP 0233</b>  |  |
| 2. <u>Zamýšľané použitie/použitia:</u>  | <b>Systém na dodatočné namontovanie výstuže s maltou na použitie v betóne.</b>   |  |
| 3. <u>Výrobca:</u>  | <b>Pozri prílohu, najmä prílohy<br/>fischerwerke GmbH &amp; Co. KG, Otto-Hahn-Straße 15, 79211 Denzlingen, Nemecko</b>                   | <b>B1- B11</b>                         |
| 4. <u>Splnomocnený zástupca:</u>  | –  |  |
| 5. <u>Systém(-y) posudzovania a overovania nemennosti parametrov:</u>   | <b>1</b>   |  |
| 6. <u>Európsky hodnotiaci dokument:</u><br>Európske technické posúdenie:<br>Orgán technického posudzovania:<br>Notifikovaný(-é) subjekt(-y):                    | <b>EAD 330087-00-0601, Edition 05/2018<br/>ETA-20/0728; 2020-11-13<br/>DIBt- Deutsches Institut für Bautechnik<br/>2873 TU Darmstadt</b> |  |
| 7. <u>Deklarované parametre:</u><br><b>Mechanická odolnosť a stabilita (BWR 1)</b><br>Charakteristická odolnosť v ťahu<br>(statické a kvázistatické zaťaženie): | Pevnosť lepeného spoja dodatočne vlepenej výstuže:<br>Redukčný faktor:<br>Súčiniteľ zvýšenia minimálnej kotevnej hĺbky:                  | Príloha C1<br>Príloha C1<br>Príloha C1 |

### **Bezpečnosť v prípade požiaru (BWR 2)**

Reakcia na oheň:  
Odolnosť proti ohňu:

Trieda (A1)  
Pevnosť lepeného spoja pri zvýšenej teplote:

Príloha C3



8. Vhodná technická dokumentácia a/alebo špecifická –  
technická dokumentácia:

Uvedené parametre výrobku sú v zhode so súborom deklarovaných parametrov. Toto vyhlásenie o parametroch sa v súlade s nariadením (EÚ) č. 305/2011 vydáva na výhradnú zodpovednosť uvedeného výrobcu.

Podpísal(-a) za a v mene výrobcu:



Dr. Oliver Geibig, konateľ oddelenia Produkt management & vývoj  
Tumlingen, 2020-11-27



Jürgen Grün, konateľ oddelenia Chemická výroba & kvalita

Toto vyhlásenie o vlastnostiach bolo vyhotovené v rôznych jazykoch. V prípade, že dôjde k rozdielnemu výkladu má anglická verzia vždy prednosť.

Príloha obsahuje dobrovoľné a doplňujúce informácie v anglickom jazyku. Tieto vychádzajú zo zákonom stanovených požiadaviek (jazykovo neutrálnych) .

## Specific Part

### 1 Technical description of the product

The subject of this European Technical Assessment is the post-installed connection, by anchoring or overlap connection joint, of reinforcing bars (rebars) in existing structures made of normal weight concrete, using the "Rebar connection with fischer injection mortar FIS V Plus" in accordance with the regulations for reinforced concrete construction.

Reinforcing bars with a diameter  $\phi$  from 8 to 28 mm or the fischer rebar anchor FRA of sizes M12 to M24 according to Annex A and the fischer injection mortar FIS V Plus or FIS VS Plus Low Speed are used for the post-installed rebar connection. The steel element is placed into a drilled hole filled with injection mortar and is anchored via the bond between embedded reinforcing bar, injection mortar and concrete.

The product description is given in Annex A.

### 2 Specification of the intended use in accordance with the applicable European assessment Document

The performances given in Section 3 are only valid if the anchor is used in compliance with the specifications and conditions given in Annex B.

The verifications and assessment methods on which this European Technical Assessment is based lead to the assumption of a working life of the rebar connection of at least 50 years. The indications given on the working life cannot be interpreted as a guarantee given by the producer, but are to be regarded only as a means for choosing the right products in relation to the expected economically reasonable working life of the works.

### 3 Performance of the product and references to the methods used for its assessment

#### 3.1 Mechanical resistance and stability (BWR 1)

Essential characteristic	Performance
Characteristic resistance under static and quasi-static loading	See Annex C 1

#### 3.2 Safety in case of fire (BWR 2)

Essential characteristic	Performance
Reaction to fire	Class A1
Resistance to fire	See Annex C 2 and C 3

### 4 Assessment and verification of constancy of performance (AVCP) system applied, with reference to its legal base

In accordance with European Assessment Document EAD No. 330087-00-0601, the applicable European legal act is: [96/582/EC].

The system(s) to be applied is (are): 1

# Installation conditions and application examples reinforcing bars, part 1

**Figure A1.1:**

Overlap joint with existing reinforcement for rebar connections of slabs and beams

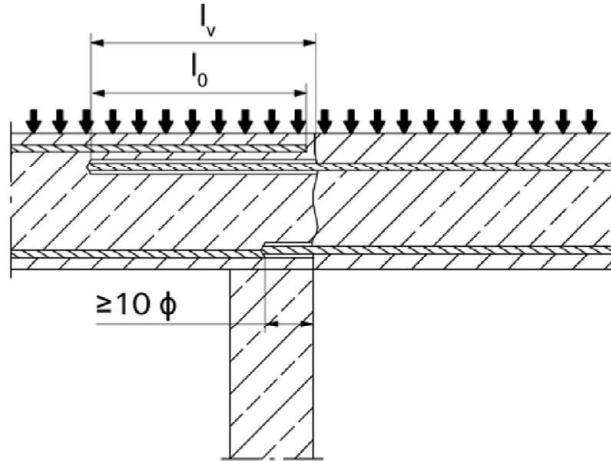

**Figure A1.2:**

Overlap joint with existing reinforcement at a foundation of a column or wall where the rebar is stressed

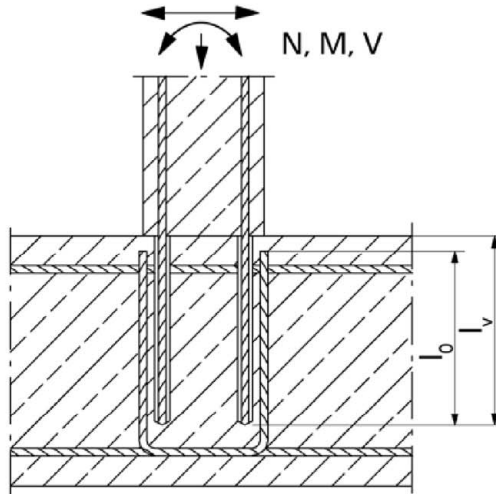

**Figure A1.3:**

End anchoring of slabs or beams (e.g. designed as simply supported)

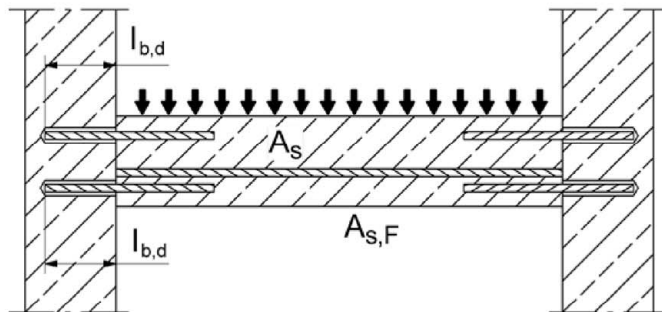

Figures not to scale

Rebar connection with fischer injection mortar FIS V Plus

**Product description**

Installation conditions and application examples reinforcing bars, part 1

**Annex A 1**

Appendix 2 / 21

## Installation conditions and application examples reinforcing bars, part 2

**Figure A2.1:**

Rebar connection for stressed primarily in compression

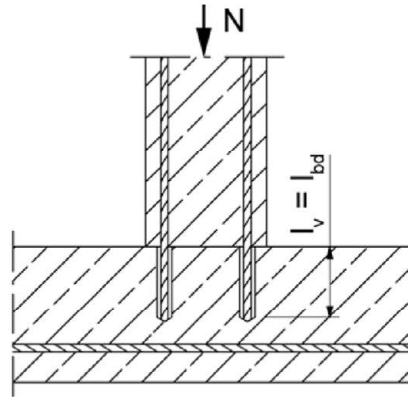

**Figure A2.2:**

Anchoring of reinforcement to cover the enveloped line of acting tensile force in the bending member

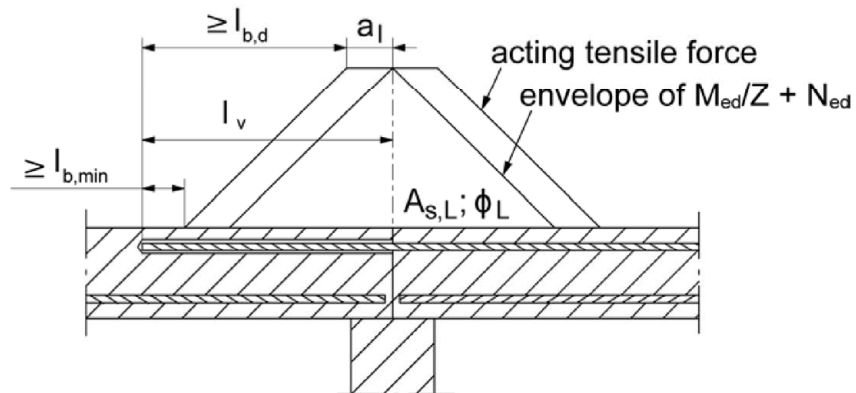

Note to **figure A1.1 to A1.3** and **figure A2.1 to A2.2**

In the figures no traverse reinforcement is plotted, the traverse reinforcement shall comply with EN 1992-1-1: 2004+AC:2010.

Preparing of joints according to **Annex B 2**

Figures not to scale

Rebar connection with fischer injection mortar FIS V Plus

**Product description**

Installation conditions and application examples reinforcing bars, part 2

**Annex A 2**

Appendix 3 / 21

# Installation conditions and application examples fischer rebar anchor FRA, part 3

**Figure A3.1:**

Lap to a foundation of a column under bending.

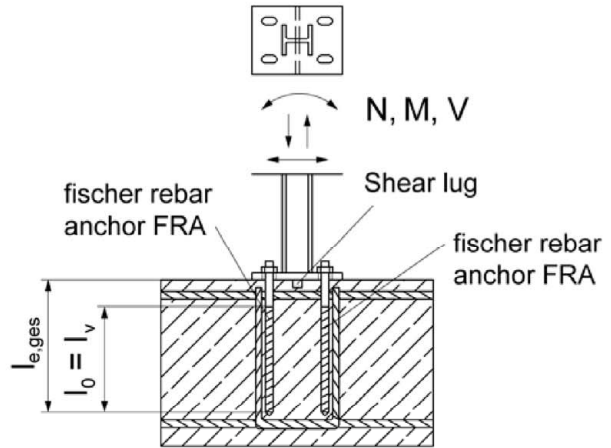

**Figure A3.2:**

Lap of the anchoring of guardrail posts. In the anchor plate, the drill holes for the fischer rebar anchors FRA have to be designed as slotted holes with axial direction to the shear force.

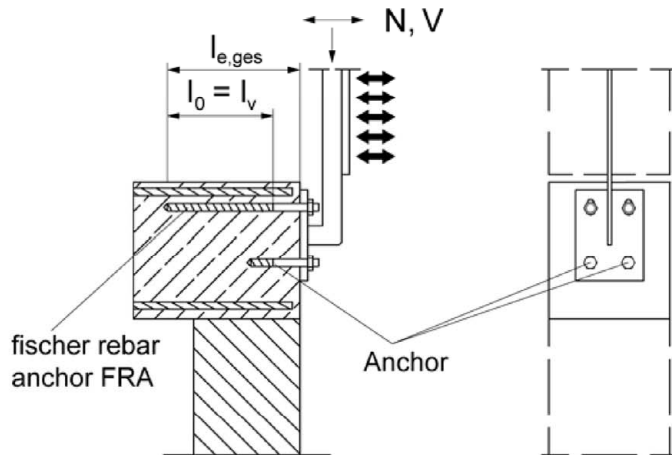

**Figure A3.3:**

Lap of the anchoring of cantilevered building components. In the anchor plate, the drill holes for the fischer rebar anchors FRA have to be designed as slotted holes with axial direction to the shear load.

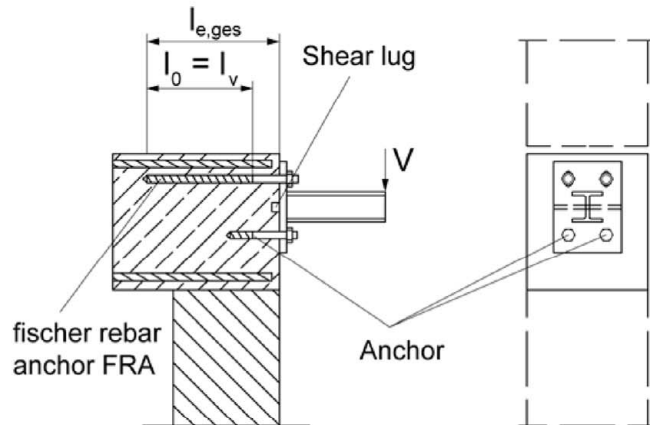

The required transverse reinforcement acc. to EN 1992-1-1:2004+AC:2010 is not shown in the figures. **The fischer rebar anchor FRA may be only used for axial tensile force.** The tensile force must be transferred by lap to the existing reinforcement of the building. The transfer of the shear force has to be ensured by suitable measure, e.g. by means of shear force or anchors with European Technical Assessment (ETA)

Figures not to scale

Rebar connection with fischer injection mortar FIS V Plus

**Product description**

Installation conditions and application examples fischer rebar anchors FRA, part 3

**Annex A 3**

Appendix 4 / 21

## Overview system components

### Injection cartridge (shuttle cartridge) FIS V Plus with sealing cap

Sizes: 350ml, 360 ml, 390 ml, 585 ml, 950 ml, 1500 ml

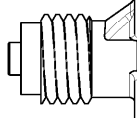
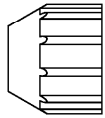

**Imprint:** fischer FIS V Plus or FIS VS Plus Low Speed, processing notes, shelf-life, hazard code, curing times and processing times (depending on temperature), piston travel scale (optional), size, volume



### Injection cartridge (coaxial cartridge) FIS V Plus with sealing cap; Sizes: 300 ml ,380 ml, 400 ml, 410 ml

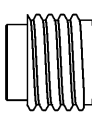
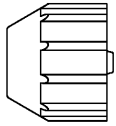

**Imprint:** fischer FIS V Plus or FIS VS Plus Low Speed, processing notes, shelf-life, hazard code, curing times and processing times (depending on temperature), piston travel scale (optional), size, volume



### Static mixer FIS MR Plus for injection cartridges up to 410 ml

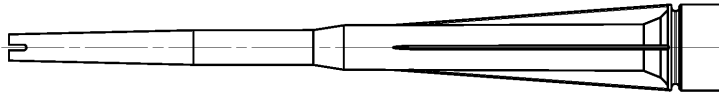

### Static mixer FIS UMR for injection cartridges from 585 ml

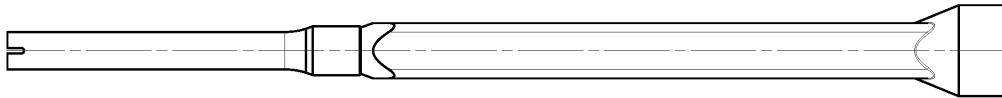

### Injection adapter and extension tube Ø 9 for static mixer FIS MR Plus; Injection adapter and extension tube Ø 9 or Ø 15 for static mixer FIS UMR

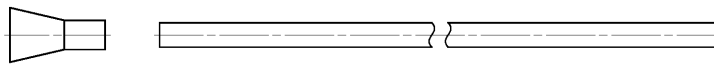

### Reinforcing bar (rebar) Sizes: $\phi 8$ , $\phi 10$ , $\phi 12$ , $\phi 14$ , $\phi 16$ , $\phi 20$ , $\phi 25$ , $\phi 28$



marking setting depth

### fischer rebar anchor FRA Sizes: M12, M16, M20, M24

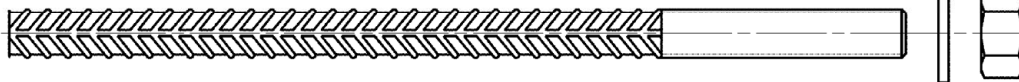

### Blow out pump ABP



Figures not to scale

Rebar connection with fischer injection mortar FIS V Plus

### Product description

Overview system components; Injection mortar, static mixer, injection adapter, reinforcing bar, rebar anchor FRA, blow out pump

**Annex A 4**

Appendix 5 / 21

## Properties of reinforcing bars (rebar)

Figure A5.1:



- The minimum value of related rip area  $f_{R,min}$  according to EN 1992-1-1:2004+AC:2010
- The maximum outer rebar diameter over the rips shall be:
  - The nominal diameter of the rip  $\phi + 2 * h$  ( $h \leq 0,07 * \phi$ )
  - ( $\phi$ : Nominal diameter of the bar;  $h$ : rip height of the bar)

Table A5.1: Installation conditions for rebars

Nominal diameter of the bar		$\phi$	8 <sup>1)</sup>		10 <sup>1)</sup>		12 <sup>1)</sup>		14	16	20	25		28
Nominal drill hole diameter	$d_0$	[mm]	10	12	12	14	14	16	18	20	25	30	35	35
Drill hole depth	$h_0$		$h_0 = l_v$											
Effective embedment depth	$l_v$		acc. to static calculation											
Minimum thickness of concrete member	$h_{min}$		$l_v + 30$ ( $\geq 100$ )						$l_v + 2d_0$					

<sup>1)</sup> Both drill hole diameters can be used

Table A5.2: Materials of rebars

Designation	Reinforcing bar (rebar)
Reinforcing bar EN 1992-1-1:2004+AC:2010, Annex C	Bars and de-coiled rods class B or C with $f_{yk}$ and $k$ according to NDP or NCL of EN 1992-1-1/NA:2013 $f_{uk} = f_{tk} = k \cdot f_{yk}$

Figures not to scale

Rebar connection with fischer injection mortar FIS V Plus

**Product description**  
Properties and materials of reinforcing bars (rebar)

**Annex A 5**

Appendix 6 / 21



## Properties of fischer rebar anchor FRA

Figure A6.1:

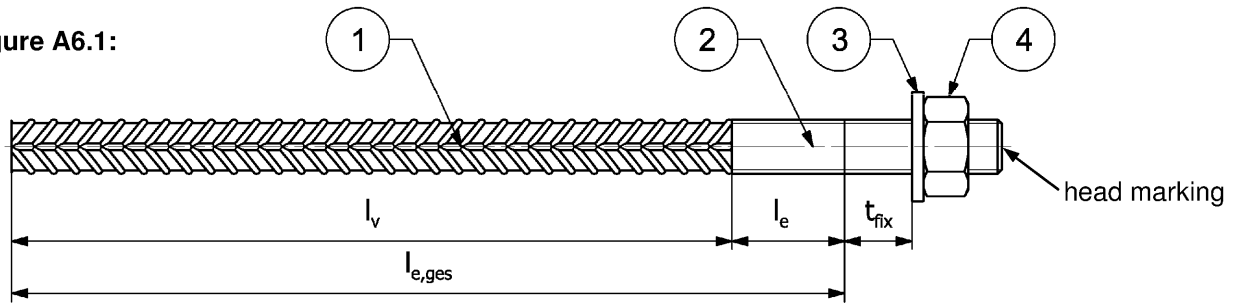

Head marking e.g.:  FRA (for stainless steel)

 FRA HCR (for high corrosion-resistant steel)

Table A6.1: Installation conditions for fischer rebar anchors FRA

Threaded diameter		M12	M16	M20	M24
Nominal diameter	$\phi$ [mm]	12	16	20	25
Width across flat	SW [mm]	19	24	30	36
Nominal drill bit diameter	$d_0$ [mm]	14 <sup>2)</sup>   16	20	25	30   35
Drill hole depth ( $h_0 = l_{e,ges}$ )	$l_{e,ges}$ [mm]	$l_v + l_e$			
Effective embedment depth	$l_v$ [mm]	acc. to static calculation			
Distance concrete surface to welded joint	$l_e$ [mm]	100			
Diameter of clearance hole in the fixture <sup>1)</sup>	Pre-positioned $\leq d_f$ [mm]	14	18	22	26
	Push through $\leq d_f$ [mm]	18	22	26	32
Minimum thickness of concrete member	$h_{min}$ [mm]	$h_0+30$ ( $\geq 100$ )	$h_0 + 2d_0$		
Maximum torque moment for attachment of the fixture	$\max T_{fix}$ [Nm]	50	100	150	150

<sup>1)</sup> For bigger clearance holes in the fixture see EN 1992-4:2018

<sup>2)</sup> Both drill bit diameters can be used

Table A6.2: Materials of fischer rebar anchors FRA

Part	Description	Materials	
		FRA	FRA HCR
1	Reinforcing bar	B500B acc. to DIN 488-1:2009	
2	Round bar with partial or full thread	Stainless steel acc. to EN 10088-1:2014	High corrosion-resistant steel acc. to EN 10088-1:2014
3	Washer	Stainless steel acc. to EN 10088-1:2014	High corrosion-resistant steel acc. to EN 10088-1:2014
4	Hexagon nut	Stainless steel acc. to EN 10088-1:2014, strength class 80; acc. to EN ISO 3506:2009	High corrosion-resistant steel acc. to EN 10088-1:2014, strength class 80; acc. to EN ISO 3506:2009

Figures not to scale

Rebar connection with fischer injection mortar FIS V Plus



**Product description**  
Properties and materials of fischer rebar anchors FRA

**Annex A 6**

Appendix 7 / 21

# Specifications of intended use (part 1)

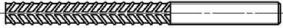
**Table B1.1:** Overview use and performance categories

Anchorages subject to		FIS V Plus with ...			
		Reinforcing bar 		fischer rebar anchor FRA 	
Hammer drilling with standard drill bit 		all sizes			
Hammer drilling with hollow drill bit (fischer "FHD", Heller "Duster Expert"; Bosch „Speed Clean“; Hilti "TE-CD, TE-YD") 		Nominal drill bit diameter ( $d_0$ ) 12 mm to 35 mm			
Static and quasi static load, in	uncracked concrete	all sizes	Tables: C1.1 C1.2 C1.3	all sizes	Tables: C1.1 C1.2 C1.3
	cracked concrete				
Installation temperature	$T_{i,min} = 0\text{ °C}$ to $T_{i,max} = +40\text{ °C}$				
Fire exposure	all sizes	Annex C3	all sizes	Annex C2	
Rebar connection with fischer injection mortar FIS V Plus					<p><b>Annex B 1</b></p> <p>Appendix 8 / 21</p>
Intended use Specifications (part 1)					

## Specifications of intended use

### Anchorage subject to:

- Static and quasi-static loads: reinforcing bar (rebar) size 8 mm to 28 mm
- Fire exposure

### Base materials:

- Compacted reinforced or unreinforced normal weight concrete without fibres according to EN 206:2013+A1:2016
- Strength classes C12/15 to C50/60 according to EN 206:2013+A1:2016
- Maximum chloride content of 0,40 % (CL 0.40) related to the cement content according to EN 206:2013+A1:2016
- Non-carbonated concrete

Note: In case of a carbonated surface of the existing concrete structure the carbonated layer shall be removed in the area of the post-installed rebar connection with a diameter of  $\phi + 60$  mm prior to the installation of the new rebar. The depth of concrete to be removed shall correspond to at least the minimum concrete cover in accordance with EN 1992-1-1 :2004+AC:2010. The foregoing may be neglected if building components are new and not carbonated and if building components are in dry conditions.

### Temperature Range:

- - 40°C to +80°C (max. short term temperature +80°C and max long term temperature +50°C).

### Installation temperature:

- 0 °C to +40 °C

### Use conditions (Environmental conditions) for fischer rebar anchors FRA

- Structures subject to dry internal conditions (fischer rebar anchors FRA and FRA HCR)
- Structures subject to external atmospheric exposure (including industrial and marine environment) and to permanently damp internal condition, if no particular aggressive conditions exist (fischer rebar anchors FRA and FRA HCR)
- Structures subject to external atmospheric exposure and to permanently damp internal condition, if other particular aggressive conditions exist (fischer rebar anchors FRA HCR)

Note: Particular aggressive conditions are e.g. permanent, alternating immersion in seawater or the splash zone of seawater, chloride atmosphere of indoor swimming pools or atmosphere with extreme chemical pollution (e.g. in desulphurization plants or road tunnels where de-icing materials are used).

### Design:

- Anchorages are designed under the responsibility of an engineer experienced in anchorages and concrete work.
- Verifiable calculation notes and drawings are prepared taking account of the forces to be transmitted.
- Design according to EN 1992-1-1:2004+AC:2010 and Annex B 3 and B 4.
- The actual position of the reinforcement in the existing structure shall be determined on the basis of the construction documentation and taken into account when designing.

### Installation:

- Dry or wet concrete
- Water filled holes
- Hole drilling by hammer drill, hollow drill or compressed air drill mode
- Overhead installation allowed
- The installation of post-installed rebar respectively fischer rebar anchor FRA shall be done only by suitable trained installer and under Supervision on site; the conditions under which an installer may be considered as suitable trained and the conditions for Supervision on site are up to the Member States in which the installation is done.
- Check the position of the existing rebars (if the position of existing rebars is not known, it shall be determined using a rebar detector suitable for this purpose as well as on the basis of the construction documentation and then marked on the building component for the overlap joint).

Rebar connection with fischer injection mortar FIS V Plus

Intended use  
Specifications (part 2)

**Annex B 2**

Appendix 9 / 21

## General construction rules for post-installed rebars

**Figure B3.1:**

- Only tension forces in the axis of the rebar may be transmitted.
- The transfer of shear forces between new concrete and existing structure shall be designed additionally according to EN 1992-1-1:2004+AC:2010.
- The joints for concreting must be roughened to at least such an extent that aggregate protrude.

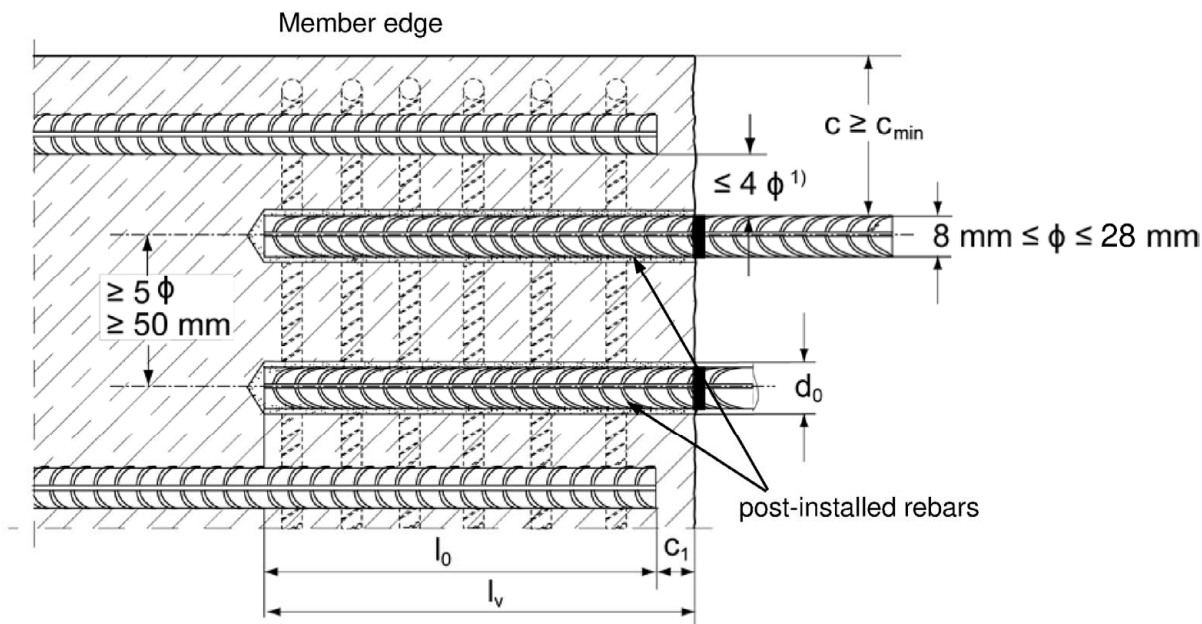

<sup>1)</sup> If the clear distance between lapped bars exceeds  $4\phi$  then the lap length shall be increased by the difference between the clear bar distance and  $4\phi$

- $c$  concrete cover of post-installed rebar  
 $c_1$  concrete cover at end-face of existing rebar  
 $c_{min}$  minimum concrete cover according to table B5.1 and to EN 1992-1-1:2004+AC:2010, Section 4.4.1.2  
 $\phi$  nominal diameter of reinforcing bar  
 $l_0$  lap length, according to EN 1992-1-1:2004+AC:2010  
 $l_v$  effective embedment depth,  $\geq l_0 + c_1$   
 $d_0$  nominal drill bit diameter, see Annex B 6

Figures not to scale

Rebar connection with fischer injection mortar FIS V Plus

**Intended use**  
 General construction rules for post-installed rebars

**Annex B 3**

Appendix 10 / 21

## General construction rules for post-installed rebar anchors FRA

Figure B4.1:

- Only tension forces in the axis of the FRA may be transmitted.
- The tension force must be transferred via an overlap joint to the reinforcement in the building part.
- The transmission of the shear load shall be ensured by appropriate additional measures, e.g. by shear lugs or by anchors with a European Technical Assessment (ETA).
- In the anchor plate, the holes for the tension anchor shall be executed as slotted holes with the axis in the direction of the shear force.

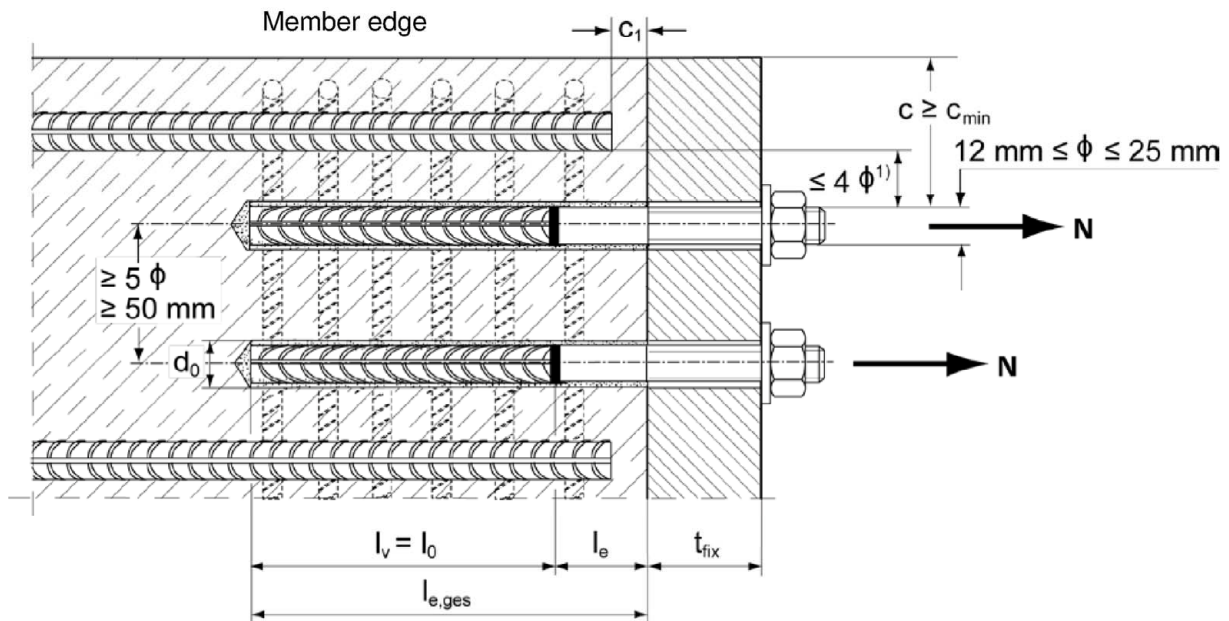

<sup>1)</sup> If the clear distance between lapped bars exceeds  $4 \phi$  then the lap length shall be increased by the difference between the clear bar distance and  $4 \phi$ .

c	concrete cover of post-installed rebar anchor FRA
$c_1$	concrete cover at end-face of existing rebar
$c_{min}$	minimum concrete cover according to table B5.1 and to EN 1992-1-1:2004+AC:2010, Section 4.4.1.2
$\phi$	nominal diameter of reinforcing bar
$l_0$	lap length, according to EN 1992-1-1:2004+AC:2010, Section 8.7.3
$l_{e,ges}$	overall embedment depth, $\geq l_0 + l_e$
$d_0$	nominal drill bit diameter, see Annex B 6
$l_e$	length of the bonded in threaded part
$t_{fix}$	thickness of the fixture
$l_v$	effective embedment depth

Figures not to scale

Rebar connection with fischer injection mortar FIS V Plus

**Intended use**  
General construction rules for post-installed rebar anchors FRA

**Annex B 4**

Appendix 11 / 21

**Table B5.1:** Minimum concrete cover  $c_{min}^{1)}$  depending of the drilling method and the drilling tolerance

Drilling method	nominal diameter of reinforcing bar $\phi$ [mm]	Minimum concrete cover $c_{min}$	
		Without drilling aid [mm]	With drilling aid [mm]
Hammer drilling with standard drill bit	$< 25$	$30 \text{ mm} + 0,06 l_v \geq 2 \phi$	$30 \text{ mm} + 0,02 l_v \geq 2 \phi$
	$\geq 25$	$40 \text{ mm} + 0,06 l_v \geq 2 \phi$	$40 \text{ mm} + 0,02 l_v \geq 2 \phi$
Hammer drilling with hollow drill bit (fischer "FHD", Heller "Duster Expert"; Bosch „Speed Clean“; Hilti "TE-CD, TE-YD")	$< 25$	$30 \text{ mm} + 0,06 l_v \geq 2 \phi$	$30 \text{ mm} + 0,02 l_v \geq 2 \phi$
	$\geq 25$	$40 \text{ mm} + 0,06 l_v \geq 2 \phi$	$40 \text{ mm} + 0,02 l_v \geq 2 \phi$
Compressed air drilling	$< 25$	$50 \text{ mm} + 0,08 l_v$	$50 \text{ mm} + 0,02 l_v$
	$\geq 25$	$60 \text{ mm} + 0,08 l_v \geq 2 \phi$	$60 \text{ mm} + 0,02 l_v \geq 2 \phi$

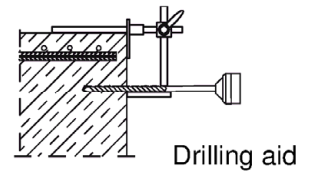

<sup>1)</sup> See Annex B3, figure B3.1 and Annex B4, figure B4.1

Note: The minimum concrete cover as specified in EN 1992-1-1:2004+AC:2010 must be observed.

**Table B5.2:** Dispensers and cartridge sizes corresponding to maximum embedment depth  $l_{v,max}$

reinforcing bars (rebar)	rebar anchor FRA	Manual dispenser	Accu and pneumatic dispenser (small)	Pneumatic dispenser (large)
		Cartridge size		
$\phi$ [mm]	thread [M]	$< 500 \text{ ml}$	$> 500 \text{ ml}$	
		$l_{v,max} / l_{e,ges,max}$ [mm]		$l_{v,max} / l_{e,ges,max}$ [mm]
8	---	1000	1000	1800
10	---		1200	
12	FRA 12		1500	
14	---		1300	
16	FRA 16	700	1000	2000
20	FRA 20		700	
25	FRA 24	500	700	
28	----			

Rebar connection with fischer injection mortar FIS V Plus

**Intended use**  
Minimum concrete cover;  
dispenser and cartridge sizes corresponding to maximum embedment depth

**Annex B 5**

Appendix 12 / 21

**Table B6.1:** Working times  $t_{work}$  and curing times  $t_{cure}$ 

Temperature in the anchorage base [°C]	Maximum working time <sup>1)</sup> $t_{work}$		Minimum curing time <sup>2)</sup> $t_{cure}$	
	FIS V Plus	FIS VS Plus Low Speed	FIS V Plus	FIS VS Plus Low Speed
>±0 to +5	13 min <sup>3)</sup>	---	3 h	6 h
>+5 to +10	9 min <sup>3)</sup>	20 min	90 min	3 h
>+10 to +20	5 min	10 min	60 min	2 h
>+20 to +30	4 min	6 min	45 min	60 min
>+30 to +40	2 min <sup>4)</sup>	4 min	35 min	30 min

1) Maximum time from the beginning of the injection to rebar / FRA setting and positioning

2) For wet concrete the curing time must be doubled

3) If the temperature in the concrete falls below 10°C the cartridge has to be warmed up to +15°C.

4) If the temperature in the concrete exceeds 30 °C the cartridge has to be cooled down to +15°C up to 20°C

**Table B6.2:** Installation tools for drilling and cleaning the bore hole and injection of the mortar

reinforcing bars (rebar)	rebar anchor FRA	Drilling and cleaning				Injection	
		Nominal drill bit diameter	Diameter of cutting edge	Steel brush diameter	Diameter of cleaning nozzle	Diameter of extension tube	Injection adapter
$\phi$ [mm]	thread [M]	$d_0$ [mm]	$d_{cut}$ [mm]	$d_b$ [mm]	[mm]	[mm]	[colour]
8 <sup>1)</sup>	---	10	≤ 10,50	11,0	---	9	---
		12	≤ 12,50	12,5	11		nature
10 <sup>1)</sup>	---	12	≤ 12,50	12,5		15	9
		14	≤ 14,50	15	19		
12 <sup>1)</sup>	FRA 12 <sup>1)</sup>	14	≤ 14,50	15		28	9 or 15
		16	≤ 16,50	17	19		
14	---	18	≤ 18,50	19		28	
16	FRA 16	20	≤ 20,55	21,5	28		
20	FRA 20	25	≤ 25,55	26,5		37	
25	FRA 24 <sup>1)</sup>	30	≤ 30,55	32	37		
		35	≤ 35,70	37			
28	---	35	≤ 35,70	37			

1) Both drill bit diameters can be used

Rebar connection with fischer injection mortar FIS V Plus

**Intended use**

Working times and curing times;  
Installation tools for drilling and cleaning the bore hole and injection of the mortar

**Annex B 6**

Appendix 13 / 21

## Safety regulations



Review the Safety Data Sheet (SDS) before use for proper and safe handling!  
Wear well-fitting protective goggles and protective gloves when working with mortar FIS V Plus / FIS VS Plus Low Speed.  
Important: Observe the instructions for use provided with each cartridge.

## Installation instruction part 1; Installation with FIS V Plus / FIS VS Plus Low Speed

### Hole drilling

Note: Before drilling, remove carbonized concrete; clean contact areas (see Annex B 2)  
In case of aborted drill holes the drill hole shall be filled with mortar.

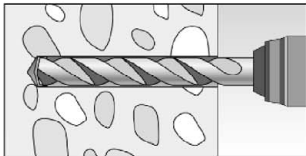
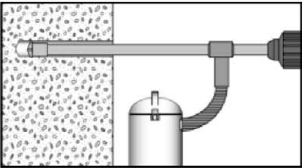
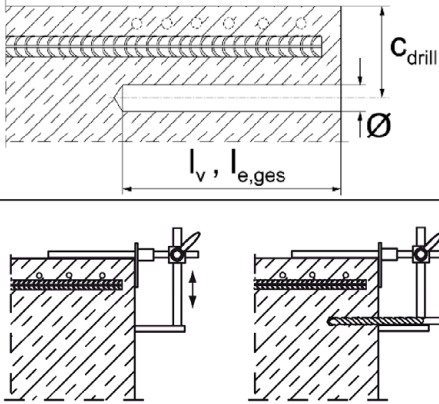
1a	<b>Hammer drilling or compressed air drilling</b> 	Drill the hole to the required embedment depth using a hammer drill with carbide drill bit set in rotation hammer mode or a pneumatic drill. Drill bit sizes see table B6.2.
1b	<b>Hammer drilling with hollow drill bit</b> 	Drill the hole to the required embedment depth using a hammer drill with hollow drill bit in rotation hammer mode. Dust extraction conditions see drill hole cleaning annex B 8. Drill bit sizes see table B6.2.
2		Measure and control concrete cover $c$ $(c_{drill} = c + \varnothing / 2)$ Drill parallel to surface edge and to existing rebar. Where applicable use fischer drilling aid.  For holes $l_v > 20$ cm use drilling aid. Three different options can be considered: A) fischer drilling aid B) Slat or spirit level C) Visual check  Minimum concrete cover $c_{min}$ see table B5.1

Rebar connection with fischer injection mortar FIS V Plus

### Intended use

Safety regulations; Installation instruction part 1, hole drilling



**Annex B 7**

Appendix 14 / 21

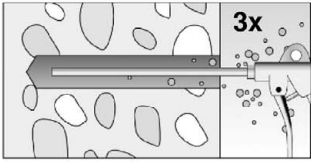
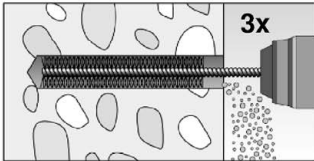
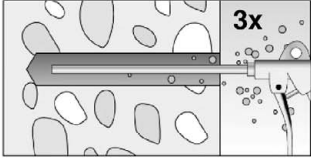
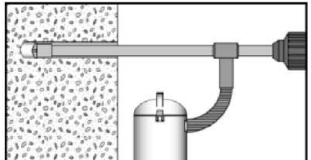

# Installation instruction part 2; Installation with FIS V Plus / FIS VS Plus Low Speed

## Drill hole cleaning

	<p><b>Hammer or compressed air drilling</b></p>	
		<p><b>Blowing</b> three times from the back of the hole with the appropriate nozzle (oil-free compressed air <math>\geq 6</math> bar) until return air stream is free of noticeable dust. Personal protective equipment must be used (see regulations Annex B 7).</p>
<p><b>3a</b></p>		<p><b>Brushing (with power drill)</b> three times with the suitable brush size (brush diameter <math>&gt;</math> drill hole diameter). Switch on the power drill after inserting the steel brush into the drill hole. The brush must produce a noticeable resistance when it is inserted into the drill hole. If this is not the case, use a new or larger brush. If necessary, check with brush inspection template. Suitable brushes see table B6.2.</p>
		<p><b>Blowing</b> three times from the back of the hole with the appropriate nozzle (oil-free compressed air <math>\geq 6</math> bar) until return air stream is free of noticeable dust. Personal protective equipment must be used. (see regulations Annex B 7).</p>
<p><b>3b</b></p>	<p><b>Hammer drilling with hollow drill bit</b></p> 	 <p>Use a suitable dust extraction system, e. g. fischer FVC 35 M or a comparable dust extraction system with equivalent performance data. Drill the hole with hollow drill bit. The dust extraction system has to extract the drill dust nonstop during the drilling process and must be adjusted to maximum power. No further drill hole cleaning necessary</p>

Rebar connection with fischer injection mortar FIS V Plus

**Intended use**  
Installation instruction part 2, drill hole cleaning

**Annex B 8**

Appendix 15 / 21

### Installation instruction part 3; Installation with FIS V Plus / FIS VS Plus Low Speed

reinforcing bars (rebar) / fischer rebar anchor FRA and cartridge preparation

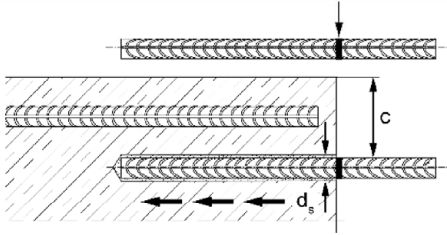
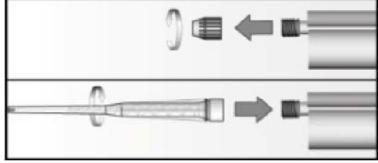
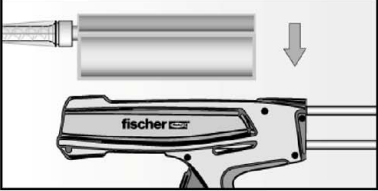
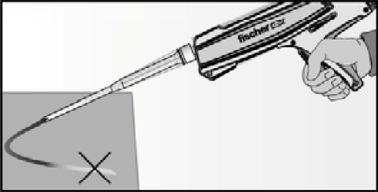
4		<p>Before use, make asure that the rebar or the rebar anchor FRA is dry and free of oil or other residue. Mark the embedment depth <math>l_v</math> (e.g. with tape) Insert rebar in borehole, to verify drill hole depth and setting depth <math>l_v</math> resp. <math>l_{e,ges}</math></p>
5		<p>Twist off the sealing cap Twist on the static mixer (the spiral in the static mixer must be clearly visible).</p>
6		<p>Place the cartridge into a suitable dispenser.</p>
7		<p>Press out approximately 10 cm of mortar until the resin is permanently grey in colour. Mortar which is not grey in colour will not cure and must be disposed.</p>

Rebar connection with fischer injection mortar FIS V Plus

#### Intended use

Installation instruction part 3,  
reinforcing bars (rebar) / fischer rebar anchor FRA and cartridge preparation

**Annex B 9**

Appendix 16 / 21

## Installation instruction part 4; Installation with FIS V Plus / FIS VS Plus Low Speed

### Injection of the mortar; borehole depth ≤ 250 mm

8a

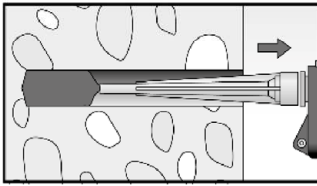

Inject the mortar from the back of the hole towards the front and slowly withdraw the mixing nozzle step by step with each trigger pull. Avoid bubbles. Fill holes approximately 2/3 full, to ensure that the annular gap between the rebar and the concrete will be completely filled with adhesive over the entire embedment length.

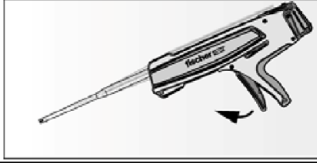

After injecting, release the dispenser. This will prevent further mortar discharge from the mixing nozzle.

### Injection of the mortar; borehole depth > 250 mm

8b

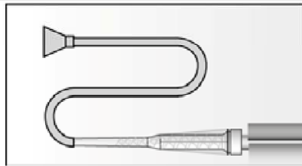

Assemble mixing nozzle FIS MR Plus or FIS UMR, extension tube and appropriate injection adapter (see table B6.2)

Mortar level mark

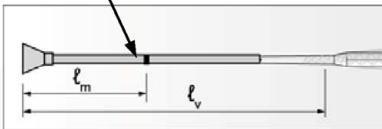

Mark the required mortar level  $l_m$  and embedment depth  $l_v$  resp.  $l_{e,ges}$  with tape or marker on the injection extension tube.

a) Estimation:

$$l_m = \frac{1}{3} * l_v \text{ resp. } l_m = \frac{1}{3} * l_{e,ges} [\text{mm}]$$

b) Precise equation for optimum mortar volume:

$$l_m = l_v \text{ resp. } l_{e,ges} \left( (1,2 * \frac{d_s^2}{d_0^2} - 0,2) \right) [\text{mm}]$$

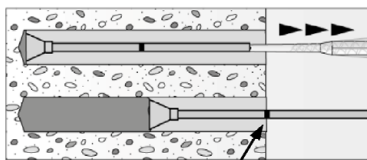

Mortar level mark

Insert injection adapter to back of the hole. Begin injection allowing the pressure of the injected adhesive mortar to push the injection adapter towards the front of the hole. Do not actively pull out!

Fill holes approximately 2/3 full, to ensure that the annular gap between the rebar and the concrete will be completely filled with adhesive over the embedment length.

When using an injection adapter continue injection until the mortar level mark  $l_m$  becomes visible.

Maximum embedment depth see table B5.2

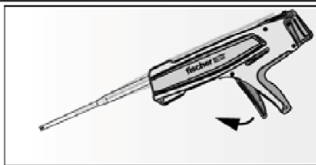

After injecting, release the dispenser. This will prevent further mortar discharge from the mixing nozzle.

Rebar connection with fischer injection mortar FIS V Plus

**Intended use**

Installation instruction part 4, mortar injection

**Annex B 10**

Appendix 17 / 21

# Installation instruction part 5; Installation with FIS V Plus / FIS VS Plus Low Speed

## Insert rebar / rebar anchor FRA

9		<p>Insert the rebar / rebar anchor FRA slowly twisted into the borehole until the embedment mark is reached.</p>
10		<p>For overhead installation, support the rebar / rebar anchor FRA and secure it from falling till mortar started to harden, e.g. using wedges.</p>
11		<p>After installing the rebar or FRA the annular gap must be completely filled with mortar.</p> <p>Proper installation</p> <ul style="list-style-type: none"> <li>• Desired embedment depth is reached <math>l_v</math>: embedment mark at concrete surface</li> <li>• Excess mortar flows out of the borehole after the rebar has been fully inserted up to the embedment mark.</li> </ul>
12		<p>Observe the working time "<math>t_{work}</math>" (see table B6.1), which varies according to temperature of base material. Minor adjustments to the rebar / rebar anchor FRA position may be performed during the working time</p> <p>Full load may be applied only after the curing time "<math>t_{cure}</math>" has elapsed (see table B 6.1)</p>
13		<p>Mounting the fixture, max <math>T_{fix}</math> see table A6.1</p>

Rebar connection with fischer injection mortar FIS V Plus

**Intended use**

Installation instruction part 5, insert rebar / rebar anchor FRA

**Annex B 11**

Appendix 18 / 21

## Minimum anchorage length and minimum lap length

The minimum anchorage length  $l_{b,min}$  and the minimum lap length  $l_{o,min}$  according to EN 1992-1-1 shall be multiply by the relevant amplification factor  $\alpha_{lb}$  according to table C1.1.

**Table C1.1:** Amplification factor  $\alpha_{lb}$  related to concrete strength class and drilling method

Concrete strength class	Drilling method	Amplification factor $\alpha_{lb}$
C12/15 to C50/60	Hammer drilling with standard drill bit	1,0
	Hammer drilling with hollow drill bit (fischer "FHD", Heller "Duster Expert"; Bosch „Speed Clean“; Hilti "TE-CD, TE-YD")	1,0
	Compressed air drilling	1,0

**Table C1.2:** Bond efficiency factor  $k_b$  for hammer drilling, hollow drilling and compressed air drilling

### Hammer drilling, hollow drilling and compressed air drilling

Rebar / rebar anchor FRA $\phi$ [mm]	Bond efficiency factor $k_b$								
	Concrete strength class								
	C12/15	C16/20	C20/25	C25/30	C30/37	C35/45	C40/50	C45/55	C50/60
8 to 28	1,00								

**Table C1.3:** Design values of the bond strength  $f_{bd,PIR}$  in N/mm<sup>2</sup> for hammer drilling, hollow drilling, compressed air drilling and for good bond conditions

$$f_{bd,PIR} = k_b \cdot f_{bd}$$

$f_{bd}$ : Design value of the bond strength in N/mm<sup>2</sup> considering the concrete strength classes and the rebar diameter according to EN 1992-1-1: 2004+AC:2010 (for all other bond conditions multiply the values by 0,7)

$k_b$ : Bond efficiency factor according to table C1.2

### Hammer drilling, hollow drilling and compressed air drilling

Rebar / rebar anchor FRA $\phi$ [mm]	bond strength $f_{bd,PIR}$ [N/mm <sup>2</sup> ]								
	Concrete strength class								
	C12/15	C16/20	C20/25	C25/30	C30/37	C35/45	C40/50	C45/55	C50/60
8 to 28	1,6	2,0	2,3	2,7	3,0	3,4	3,7	4,0	4,3

Rebar connection with fischer injection mortar FIS V Plus

#### Performance

Amplification factor  $\alpha_{lb}$ , bond efficiency factor  $k_b$ , design values of the bond strength  $f_{bd,PIR}$

**Annex C 1**

Appendix 19 / 21

**Table C2.1:** Essential characteristics of **tensile resistance** for **fischer rebar anchors FRA** under fire exposure

concrete strength classes C12/C15 to C50/60, according to EN 1992-4:2018

fischer rebar anchor FRA				M12	M16	M20	M24
Stainless steel (FRA or FRA HCR)							
Characteristic tensile resistance	R30	$\sigma_{Rk,s,fi}$	[N/mm <sup>2</sup> ]	30			
	R60			25			
	R90			20			
	R120			16			

**Design value of the steel bearing capacity  $\sigma_{Rd,s,fi}$  under fire exposure for fischer rebar anchor FRA**

The design value of the steel bearing capacity  $\sigma_{Rd,s,fi}$  under fire exposure has to be calculated by the following equation:

$$\sigma_{Rd,s,fi} = \sigma_{Rk,s,fi} / \gamma_{M,fi}$$

with:

$\sigma_{Rk,s,fi}$       Characteristic tensile resistance according to table C2.1  
 $\gamma_{M,fi}$         Partial factor according to EN 1992-1-2:2004+AC:2008

Rebar connection with fischer injection mortar FIS V Plus

**Performance**

Design value of the steel bearing capacity  $\sigma_{Rd,s,fi}$  under fire exposure for fischer rebar anchor FRA

**Annex C 2**

Appendix 20 / 21

## Design values of the bond strength $f_{bk,fi}$ under fire exposure for concrete strength classes C12/15 to C50/60 (all drilling methods)

The design value of the bond strength  $f_{bk,fi}$  under fire exposure has to be calculated by the following equation:

$$f_{bk,fi} = k_{fi}(\theta) \cdot f_{bd,PIR} \cdot \frac{\gamma_c}{\gamma_{M,fi}}$$

$$\text{If: } \theta > 74 \text{ } ^\circ\text{C} \quad k_{fi}(\theta) = \frac{24,308 \cdot e^{-0,012 \cdot \theta}}{f_{bd,PIR} \cdot 4,3} \leq 1,0$$

$$\text{If: } \theta > \theta_{\max} (317 \text{ } ^\circ\text{C}) \quad k_{fi}(\theta) = 0$$

- $f_{bk,fi}$  = Design value of the bond strength in case of fire (in N/mm<sup>2</sup>)
- $(\theta)$  = Temperature in °C in the mortar layer
- $k_{fi}(\theta)$  = Reduction factor under fire exposure
- $f_{bd,PIR}$  = Design value of the bond strength in N/mm<sup>2</sup> in cold condition according to table C1.3 considering the concrete classes, the rebar diameter, the drilling method and the bond conditions according to EN 1992-1-1:2004+AC:2010
- $\gamma_c$  = Partial factor according to EN 1992-1-1:2004+AC:2010
- $\gamma_{M,fi}$  = Partial factor according to EN 1992-1-2:2004+AC:2008

For evidence under fire exposure the anchorage length shall be calculated according to EN 1992-1-1:2004+AC:2010 Equation 8.3 using the temperature-dependent ultimate bond strength  $f_{bk,fi}$ .

**Figure C3.1:** Example graph of reduction factor  $k_{fi}(\theta)$  for concrete class C20/25 for good bond conditions

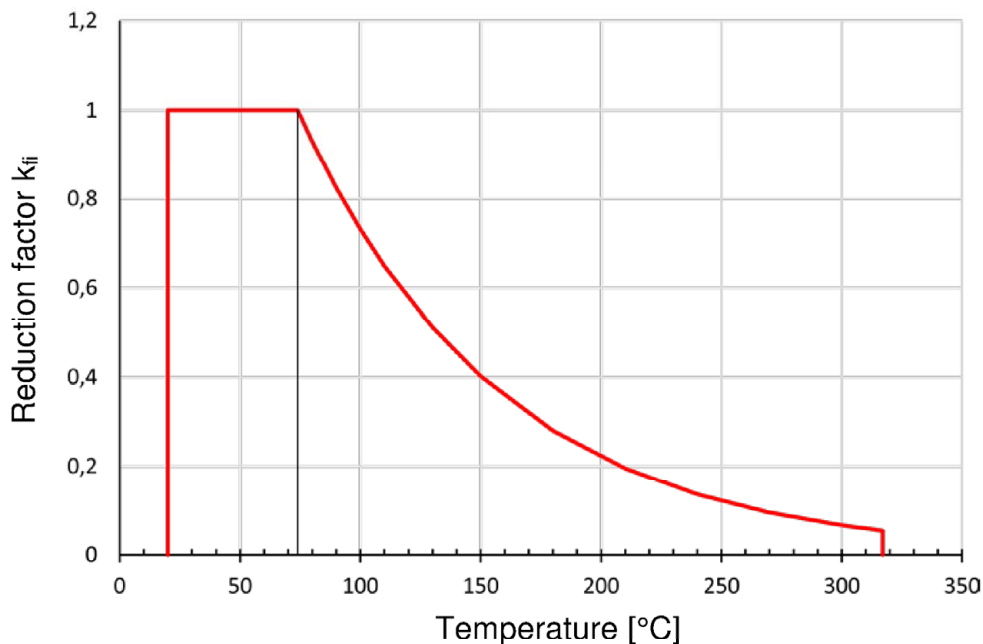

Rebar connection with fischer injection mortar FIS V Plus

**Performance**  
Design values of bond strength  $f_{bk,fi}$  under fire exposure

**Annex C 3**

Appendix 21 / 21