



VYHLÁSENIE O PARAMETROCH



č. 0078 – SK

1. Jedinečný identifikačný kód typu výrobku: **fischer skrutka do betónu ULTRACUT FBS II**

2. Zamýšľané použitie/použitia:

Produkt	Predpokladané použitie
Oceľová kotva pre použitie v betóne k upevneniu ťažkých systémov	K upevneniu a/alebo podpore nosných betónových prvkov alebo ťažkých stavebných častí ako obkladov a stropov, pozri prílohu, najmä prílohy B 1 - B 4

3. Výrobca: **fischerwerke GmbH & Co. KG, Klaus-Fischer-Straße 1, 72178 Waldachtal, Nemecko**

4. Splnomocnený zástupca: --

5. Systém(-y) posudzovania a overovania nemennosti parametrov: **1**

6a. Harmonizovaná norma: ---

Notifikovaný(-é) subjekt(-y): ---

6b. Európsky hodnotiaci dokument: **ETAG 001; 2013-04**

EAD 330011-00-0601; 2014-07

Európske technické posúdenie: **ETA-15/0352; 2016-04-12**

Orgán technického posudzovania: **DIBt**

Notifikovaný(-é) subjekt(-y): **1343 – MPA Darmstadt**

7. Deklarované parametre:

Mechanická pevnosť a stabilita (BWR 1)

Podstatný znak	Výkon
Charakteristické hodnoty únosnosti pre statické a kvázi-statické zaťaženie	Pozri prílohu, najmä prílohu C 1
Charakteristická únosnosť seizmickej odolnosti kategórie C1 a C2	Pozri prílohu, najmä prílohu C 2
Posuny pre ťahové a šmykové zaťaženie	Pozri prílohu, najmä prílohu C 4

Protipožiarna ochrana (BWR 2)

Podstatný znak	Výkon
Reakcia na oheň	Hmoždinka spĺňa požiadavky triedy A 1
Odolnosť voči ohňu	Pozri prílohu, obzvlášť prílohu C 3

8. Vhodná technická dokumentácia a/alebo špecifická technická dokumentácia: ---

Uvedené parametre výrobku sú v zhode so súborom deklarovateľných parametrov. Toto vyhlásenie o parametroch sa v súlade s nariadením (EÚ) č. 305/2011 vydáva na výhradnú zodpovednosť uvedeného výrobcu.

Podpísal(-a) za a v mene výrobcu:

Andreas Bucher, Dipl.-Ing.

Wolfgang Hengesbach, Dipl.-Ing., Dipl.-Wirtsch.-Ing.

Tumlingen, 2016-04-19

- Toto vyhlásenie o vlastnostiach bolo vyhotovené v rôznych jazykoch. V prípade, že dôjde k rozdielnemu výkladu má anglická verzia vždy prednosť.

- Príloha obsahuje dobrovoľné a doplňujúce informácie v anglickom jazyku. Tieto vychádzajú zo zákonom stanovených požiadaviek (jazykovo neutrálnych)

Specific Part

1 Technical description of the product

The fischer concrete screw ULTRACUT FBS II is an anchor made of hardened carbon steel of sizes 8, 10, 12 and 14. The anchor is screwed into a predrilled cylindrical drill hole. The special thread of the anchor cuts an internal thread into the member while setting. The anchorage is characterised by mechanical interlock in the special thread.

The product description is given in Annex A.

2 Specification of the intended use in accordance with the applicable European Assessment Document

The performances given in Section 3 are only valid if the anchor is used in compliance with the specifications and conditions given in Annex B.

The verifications and assessment methods on which this European Technical Assessment is based lead to the assumption of a working life of the anchor of at least 50 years. The indications given on the working life cannot be interpreted as a guarantee given by the producer, but are to be regarded only as a means for choosing the right products in relation to the expected economically reasonable working life of the works.

3 Performance of the product and references to the methods used for its assessment

3.1 Mechanical resistance and stability (BWR 1)

Essential characteristic	Performance
Characteristic values for resistance for static and quasi-static loads	See Annex C 1
Characteristic resistance for seismic performance categories C1 and C2	See Annex C 2
Displacements for tension and shear loads	See Annex C 4

3.2 Safety in case of fire (BWR 2)

Essential characteristic	Performance
Reaction to fire	Anchorage satisfy requirements for Class A1
Resistance to fire	See Annex C 3

3.3 Safety in use (BWR 4)

For Basic Works Requirement Safety in use the same criteria are valid as for Basic Works Requirement Mechanical resistance and stability.

4 Assessment and verification of constancy of performance (AVCP) system applied, with reference to its legal base

In accordance with guideline for European technical approval ETAG 001, April 2013, used as European Assessment Document (EAD) according to Article 66 Paragraph 3 of Regulation (EU) No 305/2011, and European Assessment Document EAD 330011-00-0601 the applicable European legal act is: [96/582/EC].

The system to be applied is: 1

Product in the installed condition

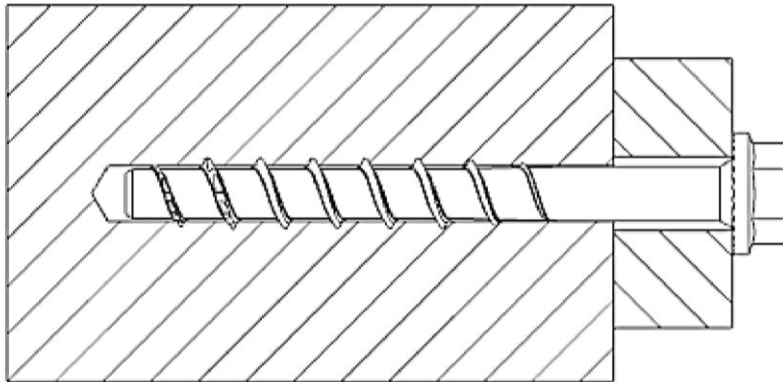

FBS II US

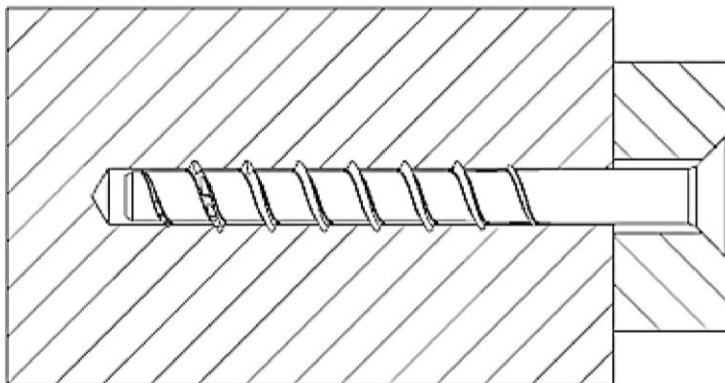

FBS II SK

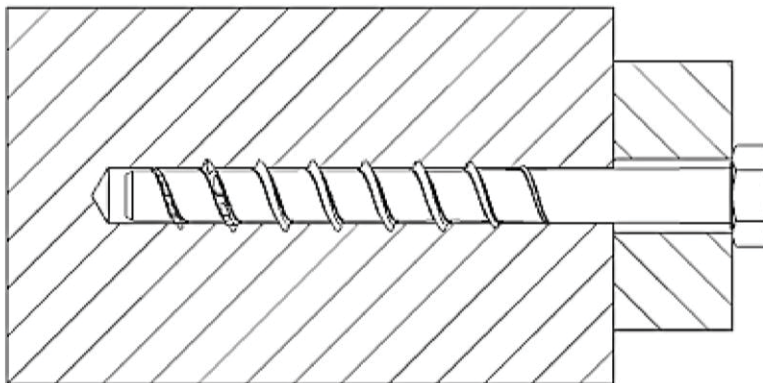







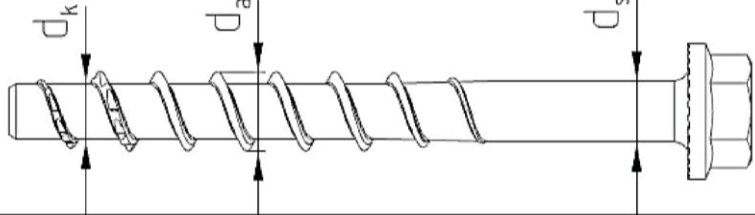

FBS II S

fischer concrete screw ULTRACUT FBS II

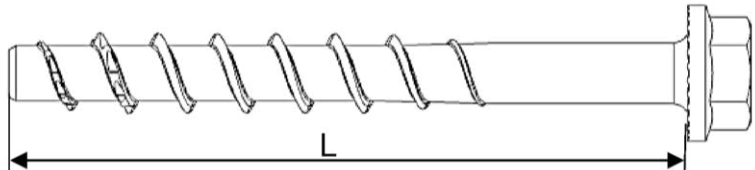
Product description
Product in the installed condition

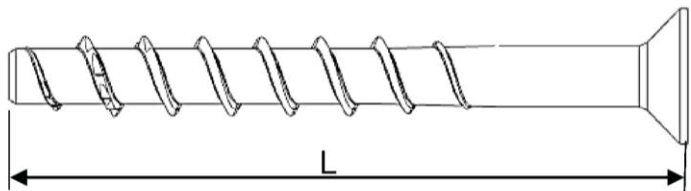
Annex A 1

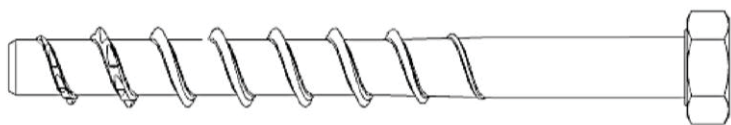
Table A1: Material and screw types

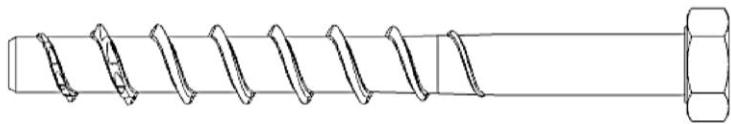
Type of screw / size			FBS II US / SK / S			
			8	10	12	14
Thread outer diameter	d_a	[mm]	10,3	12,5	14,5	16,6
Core diameter	d_k	[mm]	7,4	9,4	11,3	13,3
Shaft diameter	d_s	[mm]	8,0	9,9	11,7	13,7
Material			Hardened carbon steel; $A_{5\%} \geq 8\%$			
Coating			Zinc plated			
Hexagon head with formed washer (US)						
Hexagon head with formed washer (US TX)						
Countersunk Head (SK)						
Hexagon Head (S)						
Hexagon Head (S TX)						

Head Marking



FBS II: Product description

10: screw size

XXX: screw length

fischer concrete screw ULTRACUT FBS II

Product description
Material and screw types

Annex A 2

Specifications of intended use

Anchorage subject to:

- Static and quasi-static loads: All sizes and all embedment depths
- Seismic action for Seismic Performance Category C1 and C2: Only for maximum h_{nom} .
- Fire exposure: all sizes and all embedment depths according to Annex C3.

Base materials:

- Reinforced and unreinforced normal weight concrete according to EN 206:2013
- Strength classes C20/25 to C50/60 according to EN 206:2013
- Non-cracked or cracked concrete: All sizes and all embedment depths

Use conditions (Environmental conditions):

- Structures subject to dry internal conditions.

Design:

- Anchorages are to be designed under the responsibility of an engineer experienced in anchorages and concrete work.
- Verifiable calculation notes and drawings are to be prepared taking account of the loads to be anchored. The position of the screw is indicated on the design drawings (e.g. position of the screw relative to reinforcement or to supports, etc.).
- Anchorages under static or quasi-static actions are to be designed in accordance with:
 - ETAG 001, Annex C, design method A, Edition August 2010 or
 - CEN/TS 1992-4:2009, design method A
- Anchorages under seismic actions are to be designed in accordance with:
 - EOTA Technical Report TR 045, Edition February 2013
 - Anchorages shall be positioned outside of critical regions (e.g. plastic hinges) of the concrete structure.
 - Fastenings in stand-off installation or with a grout layer under seismic action are not allowed.
- Anchorages under fire exposure are to be designed in accordance with:
 - EOTA Technical Report TR 020, Edition May 2004 or
 - CEN/TS 1992-4:2009, Annex D
 - It must be ensured that local spalling of the concrete cover does not occur.

Installation:

- Hammer drilling or diamond drilling or hollow drilling according to Annex B4: All sizes and all embedment depths.
- Screw installation carried out by appropriately qualified personnel and under the supervision of the person responsible for technical matters on site.
- In case of aborted hole: New hole must be drilled at a minimum distance of twice the depth of the aborted hole or closer, if the hole is filled with a high strength mortar and only if the hole is not in the direction of the oblique tensile or shear load.
- Adjustability according to Annex B3 for: All sizes and all embedment depths.
- Cleaning of drill hole is not necessary when using a hollow drill or:
 - If drilling vertically upwards
 - If drilling vertical downwards and the drill hole depth has been increased. We recommend to increase the drill depth with additional $3 d_0$.
- After correct installation further turning of the screw head should not be possible
- The head of the screw must be fully engaged on the fixture and show no signs of damage.
- For Seismic Performance Category C2 applications: The gap between screw shaft and fixture must be filled with mortar; compressive strength $\geq 50 \text{ N/mm}^2$ (for example FIS V, FIS EM, FIS HB or FIS SB).

fischer concrete screw ULTRACUT FBS II

Intended Use
Specifications

Annex B 1

Table B1: Installation parameters

screw size			FBS II										
			8		10			12			14		
Nominal embedment depth	h_{nom}	[mm]	50	65	55	65	85	60	75	100	65	85	115
Nominal drill hole diameter	d_0	[mm]	8		10			12			14		
Cutting diameter of drill bits	$d_{cut} \leq$	[mm]	8,45		10,45			12,50			14,50		
Cutting diameter tolerance especially for diamond drillers	d_{cut}	[mm]	8,05 - 8,45		10,05 - 10,45			12,10 - 12,50			14,10 - 14,50		
Clearance hole diameter	d_f	[mm]	10,6 - 12,0		12,8 - 14,0			14,8 - 16,0			16,9 - 18,0		
Wrench size (US,S)	SW	[mm]	13		15			17			21		
Tx size	Tx	-	40		50			-			-		
Countersunk head diameter	d_h	[mm]	18		21			-			-		
Countersunk diameter in fixture	d_c	[mm]	20		23			-			-		
Drill hole depth ¹⁾	$h_1 \geq$	[mm]	60	75	65	75	95	70	85	110	80	100	130
Drill hole depth ¹⁾ (with adjustable setting process)	$h_1 \geq$	[mm]	70	85	75	85	105	80	95	120	90	110	140
Thickness of fixture	$t_{fix}^{3)} \geq$	[mm]	0										
	$t_{fix} \leq$	[mm]	L - h_{nom}										
Length of screw	$L_{min}^{3)} =$	[mm]	50	65	55	65	85	60	75	100	65	85	115
	$L_{max} =$	[mm]	400	415	405	415	435	410	425	450	415	435	465
Torque impact screw driver ²⁾	$T_{imp,max}$	[Nm]	600		650								

¹⁾ Cleaning of drill hole is not necessary when using a hollow drill or:

- if drilling vertical upwards
- If drilling vertical downwards and the drill hole depth has been increased. We recommend to increase the drill depth with additional 3 d_0 .

²⁾ Installation with any torque impact screw driver up to the maximum mentioned torque moment ($T_{imp,max}$). Alternatively, all other tools without a mentioned torque moment are allowed (e.g. ratchet spanner). In any case it must be secured, that after installation the head of the screw must be tight down on the fixture. An easy further turning of the screw must not be possible and the head of the screw is not damaged. The torque moments $T_{imp,max}$ are not valid for manual installation (e.g. torque wrench).

³⁾ For countersunk screws the height of the head must be added to t_{fix} and L_{min} .

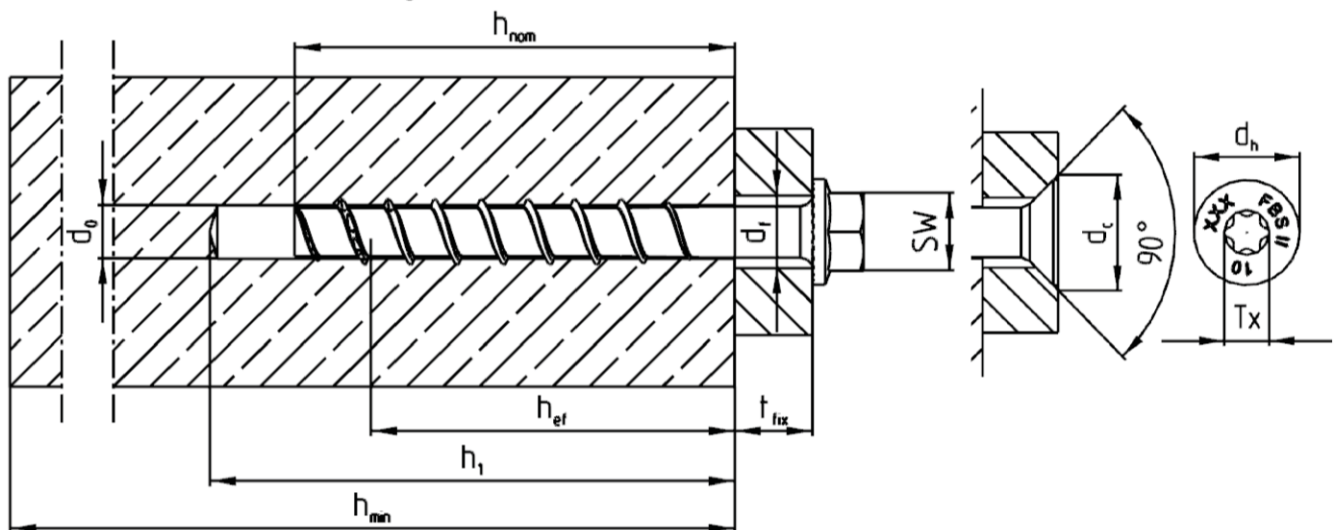

fischer concrete screw ULTRACUT FBS II

Intended Use
Installation parameters

Annex B 2

Adjustment

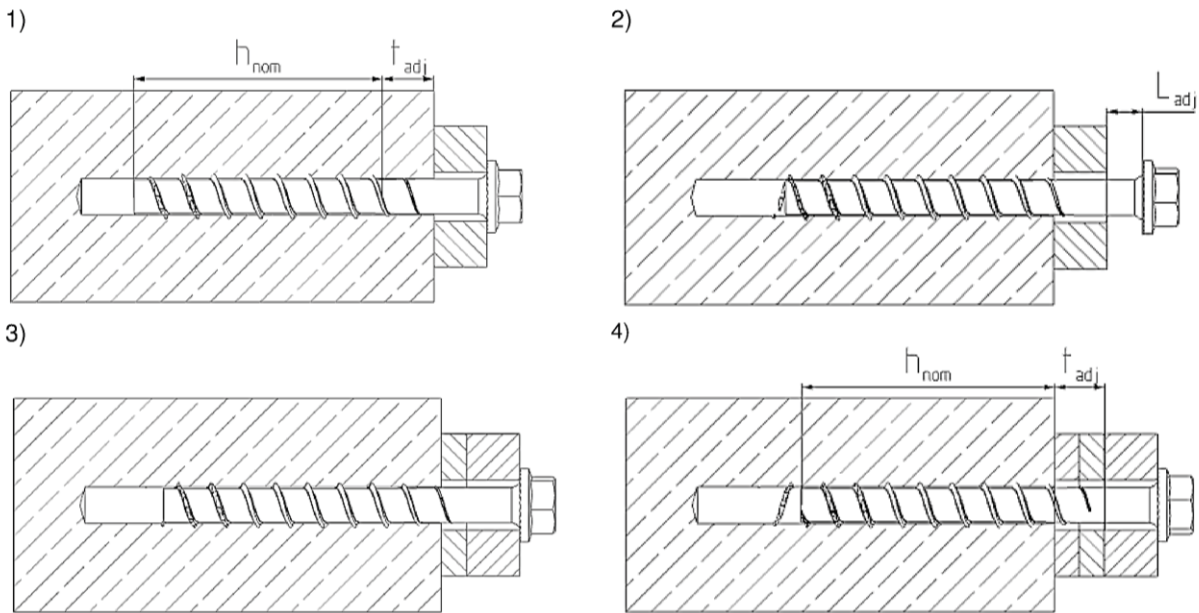

It is permissible to untighten the screw up to two times for adjustment purposes.
 Therefore the screw may be untightened to a maximum
 of $L_{adj} = 20$ mm off the surface of the initial fixture.
 The total permissible thickness of shims added during the adjustment process is $t_{adj} = 10$ mm.

Table B3: Minimum thickness of concrete members, minimum spacing and edge distance

Screw size			FBS II										
			8		10			12			14		
Nominal embedment depth	h_{nom}	[mm]	50	65	55	65	85	60	75	100	65	85	115
Minimum thickness of concrete member	h_{min}	[mm]	100	120	100	120	140	110	130	150	120	140	180
Minimum spacing	s_{min}	[mm]	35		40			50			60		
Minimum edge distance	c_{min}	[mm]	35		40			50			60		

fischer concrete screw ULTRACUT FBS II

Intended Use
 Adjustment
 Minimum thickness of concrete members, minimum spacing and edge distance

Annex B 3





Installation instruction		
		<p>Drill the hole using hammer drill, hollow drill or diamond core drill.</p> <p>Drill hole diameter d_0 and drill hole depth h_1 according to table B1</p>
<p>a) </p> <p>b)  </p>		<p>Option a) Clean the drill hole</p> <p>Option b) Cleaning of drill hole is not necessary when using a hollow drill or:</p> <ul style="list-style-type: none"> - If drilling vertically upwards or - If drilling vertically downwards and the drill hole depth has been increased. We recommend to increase the drill hole depth additional 3 times d_0.
 		<p>Installation with any torque impact screw driver up to the maximum mentioned torque moment ($T_{imp,max}$). Alternatively, all other tools without an indicated torque moment are allowed (e.g. ratchet spanner). The indicated torque moments for impact screw driver are therefore not decisive.</p>
		<p>After installation a further turning of the screw must not be possible. The head of the screw must be supported on the fixture and is not damaged.</p>
<p>1. </p> <p>2. </p> <p>3. </p>		<p>OPTIONAL: It is permissible to adjust the screw two times. Therefore the screw may be untighten to a maximum of $L_{adj} = 20$ mm off the surface of the initial fixture. The total permissible thickness of shims added during the adjustment process is $t_{adj} = 10$ mm</p>
		<p>For Seismic Performance Category C2 applications: The gap between screw shaft and fixture must be filled with mortar; compressive strength ≥ 50 N/mm² for example: FIS V, FIS EM, FIS HB or FIS SB.</p>
fischer concrete screw ULTRACUT FBS II		Annex B 4
Intended Use Installation instructions		

Table C1: Performance for static and quasi-static action

Screw size			FBS II											
			8		10			12			14			
Nominal embedment depth	h_{nom}	[mm]	50	65	55	65	85	60	75	100	65	85	115	
Steel failure for tension load and shear load														
Characteristic resistance	$N_{Rk,S}$	[kN]	35		55			76			103			
	$\gamma_{M,S,N}$	[kN]	1,4											
	$V_{Rk,S}$	[kN]	13,1	19,0	29,4		34,9	31,9		42,7	46,5		61,7	
	$\gamma_{M,S,V}$	[-]	1,5											
	$k_2^{2)}$	[-]	1,0											
	$M^0_{Rk,s}$	[Nm]	51		95			165			269			
Pullout failure														
Charact. resistance in concrete C20/25	Cracked	$N_{Rk,P}$	[kN]	6	12	9	12	- ¹⁾	- ¹⁾	- ¹⁾	- ¹⁾	- ¹⁾	- ¹⁾	- ¹⁾
	Non-cracked	$N_{Rk,P}$	[kN]	- ¹⁾										
Increasing factor concrete	C25/30	ψ_c	[-]	1,10										
	C30/37			1,22										
	C35/45			1,34										
	C40/50			1,41										
	C45/55			1,48										
	C50/60			1,55										
Installation safety factor	$\gamma_2 = \gamma_{inst}$	[-]	1,0											
Concrete cone failure and splitting failure; Concrete pryout failure														
Effective embedment depth	h_{ef}	[mm]	40	52	43	51	68	47	60	81	50	67	93	
Factor for	Cracked	$k_{cr}^{2)}$	[mm]	7,2										
	Non-cracked	$k_{ucr}^{2)}$	[mm]	10,1										
Concrete cone failure	Edge distance	$c_{cr,N}$	[mm]	1,5 h_{ef}										
	Spacing	$s_{cr,N}$	[mm]	3 h_{ef}										
Splitting failure	Edge distance	$c_{cr,sp}$	[mm]	1,5 h_{ef}										
	Spacing	$s_{cr,sp}$	[mm]	3 h_{ef}										
k-factor for pryout failure	$k^{3)} = k_3^{2)}$	[-]	1,0	2,0	1,0	2,0								
Installation safety factor	$\gamma_2^{3)} = \gamma_{inst}^{2)}$	[-]	1,0											
Concrete edge failure														
Effective length in concrete	$l_f = h_{nom}$	[mm]	50	65	55	65	85	60	75	100	65	85	115	
Nominal diameter of screw	d_{nom}	[mm]	8		10			12			14			
Adjustment														
max. thickness of adjustment layers	t_{adj}	[mm]	10											
Max. number of adjustments	n_a	[-]	2											

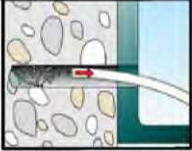
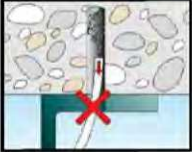
1) Pullout failure not decisive.
 2) Parameters relevant only for design according to CEN/TS 1992-4:2009
 3) Parameters relevant only for design according to ETAG 001 Annex C

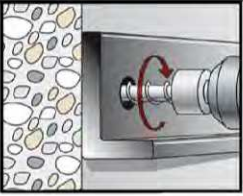
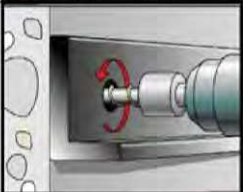
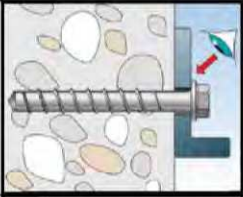
fischer concrete screw ULTRACUT FBS II

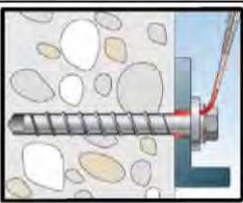
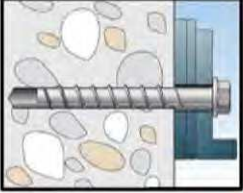
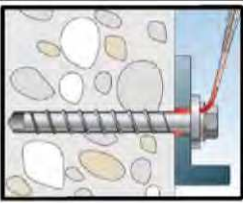
Performances
 Performance for static and quasi-static action

Annex C 1

Table C2: Characteristic values for Seismic Performance Category C1

Screw size			FBS II			
			8	10	12	14
Nominal embedment depth	h_{nom}	[mm]	65	85	100	115
Steel failure for tension load and shear load C1						
Characteristic resistance	$N_{Rk,S,C1}$	[kN]	35	55	76	103
	$V_{Rk,S,C1}$	[kN]	11,4	22,3	26,9	38,3
Pullout failure						
Characteristic resistance in cracked concrete	$N_{Rk,p,C1}$	[kN]	12	- ¹⁾		
Concrete cone failure						
Effective embedment depth	h_{ef}	[mm]	52	68	81	93
Concrete cone failure	Edge distance	$c_{cr,n}$	1,5 h_{ef}			
	Spacing	$s_{cr,n}$	3 h_{ef}			
Installation safety factor	γ_2	[-]	1,0			
Concrete pryout failure						
k-factor	k	[-]	2,0			
Concrete edge failure						
Effective length in concrete	$l_f = h_{nom}$	[mm]	65	85	100	115
Nominal diameter of screw	d_{nom}	[mm]	8	10	12	14

Table C3: Characteristic values for Seismic Performance Category C2

Gap between screw shaft and fixture must be filled with mortar

Screw size			FBS II			
			8	10	12	14
Nominal embedment depth	h_{nom}	[mm]	65	85	100	115
Steel failure for tension load and shear load C2						
Characteristic resistance	$N_{Rk,S,C2}$	[kN]	35,0	55	76,0	103
	$V_{Rk,S,C2}$	[kN]	13,3	20,4	29,9	35,2
Pullout failure						
Characteristic resistance in cracked concrete	$N_{Rk,p,C2}$	[kN]	2,1	6,0	8,9	17,1
Concrete cone failure						
Effective embedment depth	h_{ef}	[mm]	52	68	81	93
Concrete cone failure	Edge distance	$c_{cr,n}$	1,5 h_{ef}			
	Spacing	$s_{cr,n}$	3 h_{ef}			
Installation safety factor	γ_2	[-]	1,0			
Concrete pryout failure						
k-factor	k	[-]	2,0			
Concrete edge failure						
Effective length in concrete	$l_f = h_{nom}$	[mm]	65	85	100	115
Nominal diameter of screw	d_{nom}	[mm]	8	10	12	14

¹⁾ Pullout failure not decisive.

fischer concrete screw ULTRACUT FBS II

Performances
Characteristic values for Seismic Performance Category C1 and C2

Annex C 2

Table C4: Characteristic values for resistance to fire

Screw size				FBS II											
Minimum embedment depth		h_{nom}	[mm]	8		10			12			14			
				50	65	55	65	85	60	75	100	65	85	115	
Steel failure for tension load and shear load ($F_{Rk,s,fi} = N_{Rk,s,fi} = V_{Rk,s,fi}$)															
Characteristic resistance for head shape	US, S	R30	$F_{Rk,s,fi}$	[kN]	2,33		3,45			4,62			6,46		
		R60	$F_{Rk,s,fi}$	[kN]	1,82		2,73			3,66			5,11		
		R90	$F_{Rk,s,fi}$	[kN]	1,30		2,00			2,69			3,75		
		R120	$F_{Rk,s,fi}$	[kN]	1,04		1,64			2,20			3,08		
	SK, US TX, S TX	R30	$F_{Rk,s,fi}$	[kN]	2,12		2,96			-			-		
		R60	$F_{Rk,s,fi}$	[kN]	1,67		2,26			-			-		
		R90	$F_{Rk,s,fi}$	[kN]	1,21		1,56			-			-		
		R120	$F_{Rk,s,fi}$	[kN]	0,99		1,21			-			-		
	All head shapes	R30	$M^0_{Rk,s,fi}$	[Nm]	2,62		4,92			7,83			12,89		
		R60	$M^0_{Rk,s,fi}$	[Nm]	2,05		3,89			6,20			10,19		
		R90	$M^0_{Rk,s,fi}$	[Nm]	1,46		2,85			4,56			7,48		
		R120	$M^0_{Rk,s,fi}$	[Nm]	1,17		2,34			3,73			6,14		
Pullout failure															
Characteristic resistance	R30	$N_{Rk,s,fi}$	[kN]												
	R60	$N_{Rk,s,fi}$	[kN]	1,5	3,0	2,3	3,0	5,0	2,9	4,2	6,6	3,2	4,9	8,1	
	R90	$N_{Rk,s,fi}$	[kN]												
	R120	$N_{Rk,s,fi}$	[kN]	1,2	2,4	1,8	2,4	4,0	2,3	3,3	5,2	2,5	3,9	6,5	
Concrete cone failure															
Characteristic resistance	R30	$N_{Rk,s,fi}$	[kN]												
	R60	$N_{Rk,s,fi}$	[kN]	1,7	3,5	2,2	3,3	6,9	2,7	5,0	10,6	3,2	6,6	15,0	
	R90	$N_{Rk,s,fi}$	[kN]												
	R120	$N_{Rk,s,fi}$	[kN]	1,4	2,8	1,7	2,7	5,5	2,2	4,0	8,5	2,5	5,3	12,0	
Edge distance															
R30 to R120	$C_{cr,fi}$	[mm]	2 h_{ef}												
In case of fire attack from more than one side, the minimum edge distance shall be ≥ 300 mm															
Spacing															
R30 to R120	$S_{cr,fi}$	[mm]	2 $C_{cr,fi}$												
Concrete pryout failure															
R30 to R120	k	[-]	1,0	2,0	1,0	2,0									
The anchorage depth has to be increased for wet concrete by at least 30 mm compared to the given value															

fischer concrete screw ULTRACUT FBS II

Performances:
Characteristic values for resistance to fire

Annex C 3

Table C5: Displacements due to tension loads (static)

Screw size			FBS II										
			8		10			12			14		
Nominal embedment depth	h_{nom}	[mm]	50	65	55	65	85	60	75	100	65	85	115
Tension load in cracked concrete	N	[kN]	2,9	5,7	4,3	5,7	9,6	5,5	8,0	12,5	6,1	9,4	15,3
Displacement	δ_{N0}	[mm]	0,5	0,9	0,7	0,7	0,8	0,7	0,9	0,8	0,8	1,0	0,8
	$\delta_{N\infty}$	[mm]	1,3	1,0	0,7	0,7	0,8	1,3	0,9	0,8	1,1	1,0	1,1
Tension load in non - cracked concrete	N	[kN]	7,9	12,0	6,8	8,8	13,5	7,7	11,0	17,4	8,5	13,2	21,6
Displacement	δ_{N0}	[mm]	0,9	1,4	0,9	0,9	1,4	0,9	1,1	1,4	1,0	1,3	1,1
	$\delta_{N\infty}$	[mm]	1,4	1,4	1,4	1,4	1,4	1,4	1,4	1,4	1,1	1,3	1,1

Table C6: Displacements due to shear loads (static)

Screw size			FBS II										
			8		10			12			14		
Nominal embedment depth	h_{nom}	[mm]	50	65	55	65	85	60	75	100	65	85	115
Shear load in cracked and non-cracked concrete	V	[kN]	6,2	9,0	14,0	14,0	16,6	15,9	15,9	21,2	23,0	23,0	30,5
Displacement	δ_{V0}	[mm]	1,4	1,4	3,2	3,2	3,2	2,5	2,5	3,4	2,8	2,8	5,4
	$\delta_{V\infty}$	[mm]	2,0	2,1	4,9	4,9	4,9	3,8	3,8	5,1	4,2	4,2	8,1

Table C7: Displacements due to tension loads (Seismic Performance Category C2)

Screw size			FBS II										
			8		10			12			14		
Nominal embedment depth	h_{nom}	[mm]	65		85			100			115		
Displacement DLS	$\delta_{N,C2(DLS)}$	[mm]	0,5		0,8			0,9			1,3		
Displacement ULS	$\delta_{N,C2(ULS)}$	[mm]	1,7		2,8			2,7			5,0		

Table C8: Displacements due to shear loads (Seismic Performance Category C2)

Screw size			FBS II										
			8		10			12			14		
Nominal embedment depth	h_{nom}	[mm]	65		85			100			115		
Displacement DLS	$\delta_{V,C2(DLS)}$	[mm]	1,6		2,7			3,1			4,1		
Displacement ULS	$\delta_{V,C2(ULS)}$	[mm]	3,9		7,1			5,3			8,7		

fischer concrete screw ULTRACUT FBS II

Performances:
Displacements under tension and shear loads

Annex C 4